

---

# REVOLUTION **AIRY**

INNOVA SYSTEM



# Innova

S Y S T E M

---

# I NUOVI PERCORSI DELL'ARIA/ THE NEW AIR ROUTES

La materia con cui lavoriamo è la più impalpabile, invisibile ed eterea degli elementi, e al tempo stesso la più vitale. Senza forma né confini, l'aria è libera per definizione. Eppure, la sua qualità determina la qualità della vita stessa, il benessere del nostro respiro, la pulizia degli ambienti in cui viviamo.

The material we work with is the most impalpable, invisible and ethereal of elements, and at the same time the most vital. Without form or boundaries, air is free by definition. Yet, its quality determines the quality of life itself, the well-being of our breathing, the cleanliness of the environments which we live in.

Aspirarla, filtrarla, pulirla, dirigerla dove è meglio per i nostri ambienti: è questa l'arte di Airforce, il know-how che ci contraddistingue.

Drawing it in, filtering it, cleaning it and directing it where it is best for our environments: this is the art of Airforce, the know-how that sets us apart.

La collezione di cappe e piani aspiranti **INNOVA** ne è l'espressione più attuale. I suoi ingredienti? Facilità e velocità di installazione, nuove e inedite ubicazioni per i motori, soluzioni salvaspazio che ridonano a cassette sottopiano e pensili la loro originale funzione contenitiva, design rigoroso e finiture di tendenza. Piccole e grandi idee che rivoluzionano il concetto stesso di cappa e di piano cottura, ridimensionando ingombri e ridisegnando il layout dei componenti, senza timore di osare.

The **INNOVA** collection of cooker hoods and hobs is the most current expression of this. Its features? Ease and speed of installation, new and unprecedented locations for the motors, space-saving solutions that give back the original storage function to under-counter drawers and wall units, rigorous design and trendy finishes. Small and big ideas that disrupt the very concept of cooker hood and hob, re-sizing overall dimensions and redesigning the layout of components, without fear to dare.

La ricerca tecnologica in Airforce è inarrestabile e in totale sintonia con il dinamismo dell'universo cucina, di cui studia costantemente le evoluzioni, le esigenze e gli stili. Per offrire prodotti tecnologicamente avanzati, dall'appeal estetico sobrio e raffinato, in armonia con il gusto contemporaneo dell'abitare.

Technological research at Airforce is relentless and in total harmony with the dynamism of the kitchen universe, the evolutions, needs and styles of which it constantly studies. To offer technologically advanced products, with a sober and refined aesthetic appeal, in harmony with the contemporary taste of living.

---

# LA MATERIA DI CUI SIAMO FATTI/ WHAT WE ARE MADE OF

01

**RADICI SOLIDE  
E SGUARDO AL  
FUTURO/  
SOLID ROOTS AND  
AN EYE TO THE  
FUTURE**

La scelta di progettare e realizzare ogni prodotto interamente in Italia, nella nostra sede di Cerreto D'Esì, privilegiando partnership durature con fornitori eccellenti del territorio per materie prime e componenti, ci lega a doppio filo a una terra della quale condividiamo la prestigiosa tradizione manifatturiera e la pionieristica ricerca tecnologica nel campo degli elettrodomestici.

The decision to design and manufacture every product entirely in Italy, at our headquarters in Cerreto D'Esì, favouring long-lasting partnerships with excellent suppliers in the area for raw materials and components, binds us inseparably to a land whose prestigious manufacturing tradition and pioneering technological research in the field of household appliances we share.

02

**EQUILIBRIO  
PERFETTO FRA  
DESIGN E FUNZIONE/  
PERFECT BALANCE  
BETWEEN DESIGN  
AND FUNCTION**

La forma non prevarica mai la funzione nei nostri modelli di cappe e piani a induzione. Abbiamo un debole per le prestazioni: ecco perché lasciamo che emergano, in tutta la loro potenza innovativa, attraverso linee pulite e un design rigoroso. Una gamma ampia e profonda composta da oltre 150 articoli, per soddisfare ogni cliente, in ogni parte del mondo.

Form never overrides function in our induction hob and hood models. We have a penchant for performance, which is why we let it emerge, in all its innovative power, through clean lines and rigorous design. A vast and deep range of more than 150 items to satisfy every customer, anywhere in the world.

03

**INVESTIRE PER  
INNOVARE/  
INVESTING IN  
INNOVATION**

Gli investimenti in ricerca e sviluppo, design e nuove tecnologie non si fermano mai. Ci piace crescere e spostare le frontiere del possibile nel mondo delle cappe e dei piani aspiranti. Le innovazioni che apportiamo, i brevetti che depositiamo, non sono per noi dei traguardi, ma dei nuovi punti di partenza.

Investment in research and development, design and new technologies never stops. We want to grow and go the extra mile in the world of cooker hoods and hobs. The innovations we bring and the patents we file are not milestones for us, but new starting points.

04

**IL CLIENTE SEMPRE  
AL CENTRO/  
THE CUSTOMER IS  
ALWAYS THE FOCUS**

Flessibilità, rapidità e concretezza, unite a un approccio umano empatico, mai impersonale, sono alla base del servizio che offriamo. Ogni cliente Airforce può contare sull'assistenza di un referente dedicato, appassionato e altamente qualificato, sempre pronto a risolvere tempestivamente dubbi e problematiche in ogni fase, dagli incontri preliminari al post-vendita.

Flexibility, speed and concreteness, combined with an empathetic human approach that is never impersonal, form the basis of the service we offer. Every Airforce customer can rely on the support of a dedicated, passionate and highly qualified contact person, always ready to promptly resolve doubts and problems at every stage, from preliminary meetings to after-sales.

05

**POLITICA  
COMMERCIALE  
TRASPARENTE/  
TRANSPARENT  
BUSINESS POLICY**

In linea con la coraggiosa filosofia che abbiamo abbracciato sin dall'inizio, manteniamo alta la bandiera della qualità e garantiamo ai nostri clienti, professionisti al nostro pari, il massimo rispetto delle loro politiche distributive e di pricing. Creiamo partnership forti, basate sulla fiducia e sul rispetto delle esigenze commerciali di ogni cliente, poiché il successo del suo business è anche il nostro successo.

In line with the bold philosophy we have embraced from the very beginning, we hold high the banner of quality and guarantee our customers, professionals on a par with ourselves, the utmost respect for their distribution and pricing policies. We create strong partnerships based on trust and respect for each customer's business needs, because the success of their business is also our success.



# AIRFORCE: UNA STORIA E I SUOI LUOGHI/ AIRFORCE: A STORY AND ITS PLACES

Airforce, la nostra realtà, ha visto la luce a Fabriano nel 1997. Come in un percorso di crescita personale, durante oltre 25 anni di attività ci siamo evoluti, trasformandoci, crescendo e migliorando costantemente come azienda, pur rimanendo fedeli ai nostri punti di forza: la ricerca, il design e, non da ultimo, l'entusiasmo da cui tutto è nato e che continua ad alimentare ogni nostra impresa. Partendo dalla tradizione territoriale fabrianese della cappa aspirante e facendo nostre le migliori virtù del Made in Italy, siamo diventati un'eccellenza nel mercato internazionale.

Il recente trasferimento di sede riflette la nostra naturale tendenza a investire continuamente per migliorare noi stessi e i prodotti che offriamo. Grazie ad un sistema di pannelli fotovoltaici, il nostro nuovo stabilimento non solo è ecologico, ma è praticamente autosufficiente dal punto di vista energetico. Inoltre, l'ottimizzazione logistica e produttiva della nuova sede di Cerreto d'Esi ci fornisce basi solide per affrontare con sicurezza le sfide tecnologiche del futuro.

Airforce, our company, saw the light in Fabriano in 1997. As in a path of personal growth, during over 25 years of activity we have evolved, transformed, grown and constantly improved as a company, while remaining faithful to our strengths: research, design and, last but not least, the enthusiasm from which everything was born and which continues to fuel every one of our undertakings. Starting from the Fabriano territorial tradition of the extractor hood and making the best virtues of Made in Italy our own, we have become an excellence in the international market.

The recent headquarters move reflects our natural tendency to continually invest in improving ourselves and the products we offer. Thanks to a system of photovoltaic panels, our new factory is not only ecological, but is practically self-sufficient from an energy point of view. Furthermore, the logistical and production optimization of the new headquarters in Cerreto d'Esi provides us with solid foundations to confidently face the technological challenges of the future.



---

# INDICE/ INDEX

---

01	Visio	PAG. 12
02	Slim	PAG. 18
03	Artis	PAG. 22
04	Inside Evo	PAG. 28
05	Inside In	PAG. 34
06	Inner	PAG. 36
07	Compact In	PAG. 38
08	Compact Up	PAG. 40
09	Easy Up	PAG. 47
10	Easy Fit	PAG. 54

---

---

**PIANI  
ASPIRANTI/  
ASPIRATION  
HOBS**

I N N O V A   S Y S T E M



# VISIO



## VISIO PRO

VERSIONE PRO CON COMANDO TOUCH A 5 SLIDER SEPARATI.  
PRO version with 5 separate slider touch control.



# THE EVOLUTION OF SPACE

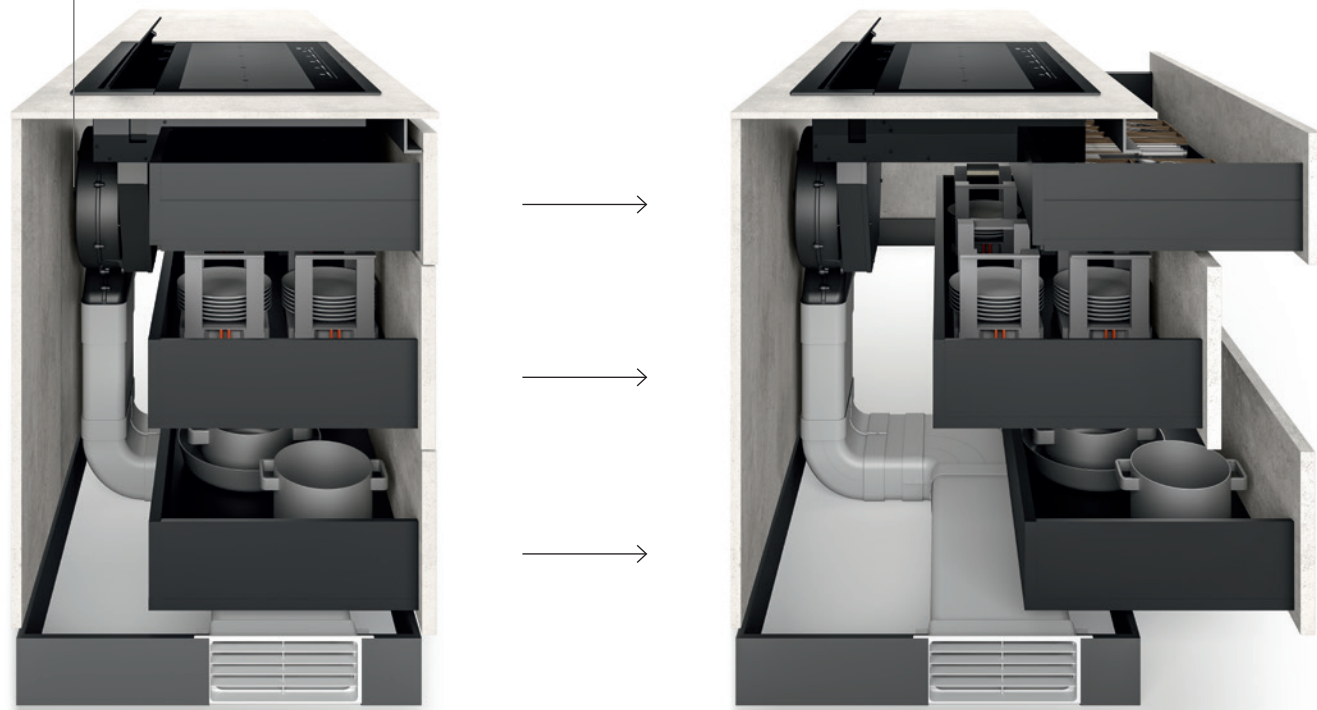

**P**rodotto pionieristico, enfant prodige della gamma, grazie al posizionamento verticale del motore sul retro, Visio rende completamente funzionante e funzionale il primo cassetto della base che lo ospita. Un sogno nel "cassetto" che diventa realtà.

**A** pioneering product, enfant prodige of the range, thanks to the vertical positioning of the motor at the back, Visio makes the first drawer of the base that houses it fully functional. A secret 'wish' that coming true.



# VISIO



L'innovazione sposta i limiti del possibile: facilità e versatilità d'installazione del motore rendono questo piano utilizzabile non solo su basi standard da sessanta, ma anche da settanta centimetri e oltre. Funzionale e stilosa la serigrafia matt antigraffio sul piano, che delimita la zona dei fuochi. Piacere tattile e visivo.

Innovation pushes the boundary of possibility: ease and versatility of the motor installation make this hob usable not only on standard bases measuring 60 cm, but also 70 cm and more. Functional and stylish is the scratch-resistant matt screen-printing on the hob, which delimits the hot zone. Tactile and visual pleasure.

VISIO PLUS

VERSIONE PLUS CON COMANDO TOUCH SLIDER BLACK WINDOW.  
PLUS version with Black Window slider touch control.

VISION BEYOND LIMITS



VISIO PRO

ASPIRAZIONE/ASPIRATION

PORTATA IEC iec air flow	665
LIVELLO SONORO Noise level	42/67/71 dB(A)
ASSORBIMENTO TOTALE Total absorption	165W
FILTRI Filters	FILTRI GRASSO METALLICI, LAVABILI Washable metallic grease filters FILTRI GRASSO TWIN, CON FILTRO ODORI INTEGRATO, OPTIONAL Twin grease filters, with integrated odour filter, optional FILTRI ODORE CERAMICI LONG LIFE DISPONIBILI, OPTIONAL Long life ceramic odour filters available, optional

COTTURA/COOKING

ZONE COTTURA Cooking zones	4 190x210 mm 4x2,1 KW (Booster 3KW)
POTENZA MASSIMA Max power	7,4 KW
LIMITATORE DI POTENZA Power limiter	PRO: 1/1,5/2,8/3,5/3,7/4,5/6/7,4KW PLUS: Power Management min. 1,4KW max 7,4KW
ZONE BRIDGE Bridge zone	2, SINISTRA E DESTRA 2, left and right

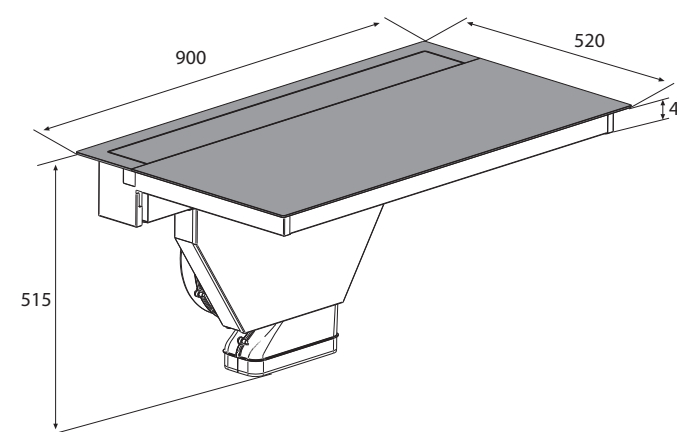

DATI TECNICI/TECHNICAL DATA

COMANDO / Control	PRO: COMANDO TOUCH A 5 SLIDER SEPARATI, 4 ZONE DI COTTURA + ASPIRAZIONE, 9P+1 INTENSIVA/BOOSTER PRO: 5 separate slider touch control, 4 cooking zones + aspiration, 9P+1 intensive/booster PLUS: COMANDO TOUCH SLIDER BLACK WINDOW, 4 ZONE DI COTTURA + ASPIRAZIONE, 9P+1 INTENSIVA/BOOSTER PLUS: Black window touch slider control, 4 cooking zones + aspiration, 9P+1 intensive/booster
DIMENSIONE / size	90x52
FORATURA / cutout	860x485 mm
FINITURA / finish	VETRO NERO CON SERIGRAFIA EFFETTO MATTE Black glass with matte effect silk-screen printing
DIEMNSIONI USCITA ARIA / air outlet dimension	222x89 mm

CARATTERISTICHE/FEATURES

- MOTORE POSTERIORE VERTICALE, CHE PERMETTE DI INSTALLARE IL PRIMO CASSETTO FUNZIONALE SOTTO AL PIANO COTTURA / Vertical rear motor, which allows the first functional drawer to be installed under the hob
- COOKING CHEF (PER VERSIONE PRO) / Cooking Chef (for PRO version)
- FUNZIONE SCALDAVIVANDE / Warming function
- APERTURA AUTOMATICA / Automatic opening
- LIMITATORE DI POTENZA REGOLABILE SU 8 LIVELLI (PRO) / Power limiter adjustable on 8 levels (PRO)
- LIMITATORE DI POTENZA CON POWER MANAGEMENT (PLUS) / Power limiter with Power Management (PLUS)
- ZERO-MOISTURE SYSTEM / Zero-Moisture System
- INSTALLABILE IN MODALITÀ ASPIRANTE O FILTRANTE/ Installable in extraction or recirculation mode



**E**legante evoluzione di un prodotto iconico della gamma, con posizionamento del motore on-board per un'installazione agevole e ultrarapida. La zona aspirante orizzontale, che segue armoniosamente l'allineamento dei quattro fuochi, ammicca sul retro, impreziosita dalla nuova veletta in alluminio. Tutto, rigorosamente, black.

**E**legant evolution of an iconic product in the range, with on-board motor positioning for easy and ultra-fast installation. The horizontal suction zone, which harmoniously follows the alignment of the four hot zones, hints at the back, decorated with new aluminium plate. All strictly in black.

# SLIM

## SLIM PLUS

VERSIONE PLUS CON COMANDO TOUCH SLIDER  
BLACK WINDOW.  
PLUS version with Black Window slider touch control.

Il contrasto fra la texture matt della zona cottura e la finitura lucida circostante esalta la bellezza del materiale vetro, creando una raffinata variazione sul tema induzione. Un solo comando a scomparsa, con luce led bianca e invisibile da spento, controlla con discrezione le funzioni di cottura e aspirazione, senza interrompere l'estetica del piano.

## WELCOME ON-BOARD

The contrast between the matt texture of the cooking zone and the surrounding glossy finish enhances the beauty of the glass material, creating a refined variation on the induction theme. A single concealed control, with white LED light and invisible when switched off, discreetly controls the cooking and extraction functions, without interrupting the aesthetics of the hob.



SLIM PLUS

### ASPIRAZIONE/ASPIRATION

PORTATA IEC Iec air flow	665
LIVELLO SONORO Noise level	42/67/71 dB(A)
ASSORBIMENTO TOTALE Total absorption	165W
FILTRI Filters	FILTRI GRASSO METALLICI, LAVABILI Washable metallic grease filters FILTRI GRASSO TWIN, CON FILTRO ODORI INTEGRATO, OPTIONAL Twin grease filters, with integrated odour filter, optional FILTRI ODORE CERAMICI LONG LIFE DISPONIBILI, OPTIONAL Long life ceramic odour filters available, optional

### DATI TECNICI/TECHNICAL DATA

COMANDO / Control	PRO: COMANDO TOUCH A 5 SLIDER SEPARATI, 4 ZONE DI COTTURA + ASPIRAZIONE, 9P+1 INTENSIVA/BOOSTER PRO: 5 separate slider touch control, 4 cooking zones + aspiration, 9P+1 intensive/booster PLUS: COMANDO TOUCH SLIDER BLACK WINDOW, 4 ZONE DI COTTURA + ASPIRAZIONE, 9P+1 INTENSIVA/BOOSTER PLUS: Black window touch slider control, 4 cooking zones + aspiration, 9P+1 intensive/booster
DIMENSIONE / size	90x52
FORATURA / cutout	860x485 mm
FINITURA / finish	VETRO NERO CON SERIGRAFIA EFFETTO MATTE Black glass with matte effect silk-screen printing
DIEMNSIONI USCITA ARIA / air outlet dimension	222x89 mm

### SLIM PRO

VERSIONE PRO CON COMANDO TOUCH A 5 SLIDER SEPARATI.  
PRO version with 5 separate slider touch control.



### COTTURA/COOKING

ZONE COTTURA Cooking zones	4 190x210 mm 4x2,1 KW (Booster 3KW)
POTENZA MASSIMA Max power	7,4 KW
LIMITATORE DI POTENZA Power limiter	PRO: 1/1,5/2,8/3,5/3,7/4,5/6/7,4KW PLUS: Power Management min. 1,4KW max 7,4KW
ZONE BRIDGE Bridge zone	2, SINISTRA E DESTRA 2, left and right

### CARATTERISTICHE/FEATURES

COOKING CHEF (PER VERSIONE PRO) / Cooking Chef (for PRO version)
FUNZIONE SCALDAVIVANDE / Warming function
APERTURA AUTOMATICA / Automatic opening
LIMITATORE DI POTENZA REGOLABILE SU 8 LIVELLI (PRO) / Power limiter adjustable on 8 levels (PRO)
LIMITATORE DI POTENZA CON POWER MANAGEMENT (PLUS) / Power limiter with Power Management (PLUS)
INSTALLABILE IN MODALITÀ ASPIRANTE O FILTRANTE / Installable in extraction or recirculation mode POSSIBILITÀ DI INSTALLAZIONE FILTRANTE CON ESTRAZIONE DELL'ARIA NEL VUOTO SANITARIO / Possibility of recirculating installation with air extraction in the plumbing space

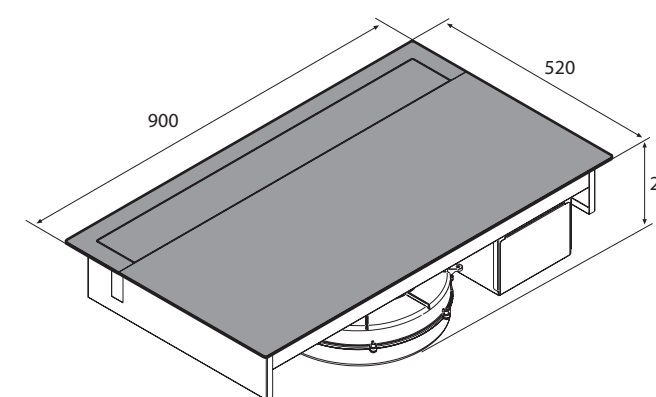



Quando si dice mettere al centro l'aspirazione. Artis lo fa sul serio, affidandosi alla ricerca creativa e al design. Il risultato estetico rompe gli schemi e al tempo stesso rende il filtraggio letteralmente a portata di fumi, per una cooking experience pulita e piacevole.

Talk about putting the focus on 'aspiration'. Artis does so seriously, relying on creative research and design. The aesthetic result breaks the rules and at the same time literally filters the fumes, for a clean and pleasant cooking experience.

# ARTIS

## ARTIS PLUS

VERSIONE PLUS CON  
COMANDO TOUCH SLIDER  
BLACK WINDOW.  
PLUS version with Black  
Window slider touch control.



Non è solo bello e centrato: ha anche i numeri. Disponibile in tre larghezze sessanta, ottanta e ottantatre centimetri, Artis risponde con dinamismo alle continue evoluzioni della cucina componibile. I ventuno centimetri di ingombro in altezza rendono Artis una perla rara nel mondo dei piani aspiranti.

It is not only beautiful and centred: it also has the numbers. Available in three widths of 60, 80 and 83 cm, Artis responds dynamically to the continuous evolution of the modular kitchen. The height of 21 cm makes Artis a real gem in the world of extraction hobs.

STUNNING,  
SKILLED AND  
CENTRED

ARTIS PRO

VERSIONE PRO CON COMANDO TOUCH A 5 SLIDER SEPARATI.  
PRO version with 5 separate slider touch control.



ARTIS PLUS,  
60 cm

ASPIRAZIONE/ASPIRATION

PORTATA IEC iec air flow	570
LIVELLO SONORO Noise level	39/64/70 dB(A)
ASSORBIMENTO TOTALE Total absorption	165W
FILTRI Filters	FILTRI GRASSO METALLICI, LAVABILI Washable metallic grease filters FILTRI GRASSO TWIN, CON FILTRO ODORI INTEGRATO, OPTIONAL Twin grease filters, with integrated odour filter, optional

DATI TECNICI/TECHNICAL DATA

COMANDO / Control	PRO: COMANDO TOUCH A 5 SLIDER SEPARATI, 4 ZONE DI COTTURA + ASPIRAZIONE, 9P+1 INTENSIVA/BOOSTER PRO: 5 separate slider touch control, 4 cooking zones + aspiration, 9P+1 intensive/booster PLUS: COMANDO TOUCH SLIDER BLACK WINDOW, 4 ZONE DI COTTURA + ASPIRAZIONE, 9P+1 INTENSIVA/BOOSTER PLUS: Black window touch slider control, 4 cooking zones + aspiration, 9P+1 intensive/booster
DIMENSIONE / size	83x52 cm 80x52 cm 60x52cm
FORATURA / cutout	60 cm: 562x495 mm 80/83 cm: 762x495 mm
FINITURA / finish	VETRO NERO CON SERIGRAFIA EFFETTO MATTE Black glass with matte effect silk-screen printing
DIEMNSIONI USCITA ARIA / air outlet dimension	222x89 mm

COTTURA/COOKING

ZONE COTTURA Cooking zones	4 190x210 mm 4x2,1 KW (Booster 3KW)
POTENZA MASSIMA Max power	7,4 KW
LIMITATORE DI POTENZA Power limiter	PRO: 1/1,5/2,8/3,5/3,7/4,5/6/7,4KW PLUS: Power Management min. 1,4KW max 7,4KW
ZONE BRIDGE Bridge zone	2, SINISTRA E DESTRA 2, left and right

CARATTERISTICHE/FEATURES

- COOKING CHEF (PER VERSIONE PRO) / Cooking Chef (for PRO version)
- FUNZIONE SCALDAVIVANDE / Warming function
- APERTURA AUTOMATICA / Automatic opening
- LIMITATORE DI POTENZA REGOLABILE SU 8 LIVELLI (PRO) / Power limiter adjustable on 8 levels (PRO)
- LIMITATORE DI POTENZA CON POWER MANAGEMENT (PLUS) / Power limiter with Power Management (PLUS)
- INSTALLABILE IN MODALITÀ ASPIRANTE O FILTRANTE / Installable in extraction or recirculation mode
- POSSIBILITÀ DI INSTALLAZIONE FILTRANTE CON ESTRAZIONE DELL'ARIA NEL VUOTO SANITARIO / Possibility of recirculating installation with air extraction in the plumbing space

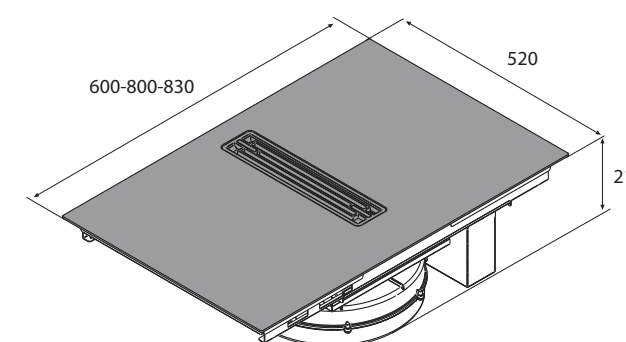



---

# INTEGRATE/ BUILT IN

I N N O V A   S Y S T E M

---

# INSIDE EVO







INSIDE EVO  
INSIDE IN

SPACE  
FOR THE  
WALL  
UNIT

**P**ensare diverso è il primo passo per concepire una proposta realmente innovativa. Inside Evo ed Inside In ne sanno qualcosa, con il loro canale di aspirazione verticale a profondità ridotta celato nella parte posteriore del mobile e il motore posizionato in alto. Per una perfetta fruibilità del pensile.

**T**hinking differently is the first step to conceiving a truly innovative offer. Inside Evo and Inside In know a thing or two about this, with their shallow vertical extraction channel concealed in the back of the unit and the motor positioned above. For perfect usability of the wall unit.



INSIDE  
EVO



## NEW AIR BEHIND THE SCENES

**F**orte delle sue eccellenti prestazioni dietro le quinte, questa cappa built-in dalla presenza discreta lascia agli arredi il ruolo di protagonisti della scena. La sottile zona di aspirazione e i comandi a vista fanno capolino sotto il pensile, in tutta la loro funzionale eleganza.

**S**trengthened by its excellent behind-the-scenes performance, this discreet built-in hood allows the furnishings to be the protagonists. The slim extraction area and visible controls peep out from under the wall unit in all their functional elegance.



### PRESTAZIONI/PERFORMANCE

PORTATA IEC iec air flow	490 M <sup>3</sup> /h
63/69/71 DB(A)	49/59/65 dB(A)
ASSORBIMENTO TOTALE Total absorption	244,6W

### DATI TECNICI/TECHNICAL DATA

COMANDO Control	PULSANTIERA ELETTRONICA SOFT TOUCH A 4 VELOCITÀ (3+1i) 4 speeds soft touch electronic push button (3+1i)
FILTRI Filters	FILTRI GRASSO METALLICI Washable metallic grease filters FILTRI GRASSO TWIN, CON FILTRO ODORI INTEGRATO, OPTIONAL Twin grease filters, with integrated odour filter, optional
PESO weight	
DIMENSIONI Size	60/90 CM
FINITURA finish	ACCIAIO INOX O NERA Stainless steel or black
DIEMNSIONI USCITA ARIA air outlet dimension	ø150 mm
FORATURA cut-out	



ENERGY CLASS

WASHABLE  
GREASE FILTERSLONG LIFE  
FILTERSDOUBLE  
MOTORSPERIMETER  
ASPIRATIONELECTRIC HOB  
MIN. DISTANCEGAS HOB  
MIN. DISTANCE

### ILLUMINAZIONE/LIGHTING

LAMPADE lamps	2x2,3W Bar Led
TEMPERATURA COLORE color temperature	3500K
INTENSITÀ intensity	260 Lux

### CARATTERISTICHE/FEATURES

2 MOTORI 2 motors
ALLOGGIAMENTO MOTORI POSIZIONATO NELLA PARTE SUPERIORE DEL PENSILE, PER UNA MAGGIORE FRUIBILITÀ DELLO SPAZIO DISPONIBILE Motor housing positioned in the upper part of the wall unit, for greater usability of the available space
CANALE DI ASPIRAZIONE POSIZIONATO POSTERIORMENTE Aspiration channel positioned at the back
TIMER

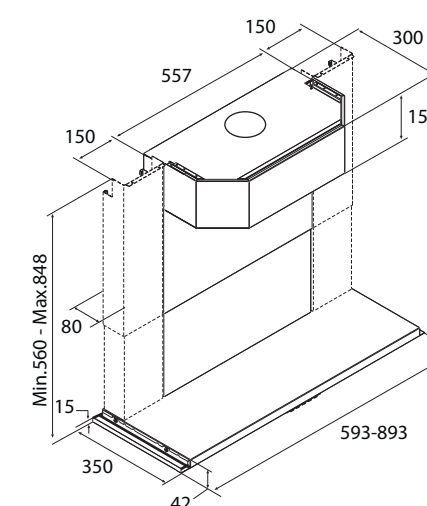



# INSIDE IN

Il pensile cappa ritrova il suo ruolo, recuperando uno spazio contenitivo prezioso nell'economia della cucina. Totalmente nascosta, Inside-in ospita i suoi comandi lungo il bordo del fondo pensile, lasciando al design della cucina tutti i riflettori: connubio perfetto di pulizia dell'aria e pulizia formale.

The hood unit regains its role, recovering valuable storage space in the economics of the kitchen. Totally concealed, Inside in houses its controls along the edge of the wall unit bottom, leaving the spotlight on the kitchen design: a perfect combination of air and formal cleanliness.



## PRESTAZIONI/PERFORMANCE

PORTATA IEC Iec air flow	490 M <sup>3</sup> /h
63/69/71 DB(A)	49/59/65 dB(A)
ASSORBIMENTO TOTALE Total absorption	244,6W

## DATI TECNICI/TECHNICAL DATA

COMANDO Control	PULSANTIERA ELETTRONICA SOFT TOUCH A 4 VELOCITÀ (3+1) 4 speeds soft touch electronic push button (3+1)
FILTRI Filters	FILTRI GRASSO METALLICI Washable metallic grease filters FILTRI GRASSO TWIN, CON FILTRO ODORI INTEGRATO, OPTIONAL Twin grease filters, with integrated odour filter, optional
PESO weight	
DIMENSIONI Size	60/90 CM
FINITURA finish	ACCIAIO INOX O NERA Stainless steel or black
DIEMNSIONI USCITA ARIA air outlet dimension	ø150 mm
FORATURA cut-out	



ENERGY CLASS

WASHABLE  
GREASE FILTERSLONG LIFE  
FILTERSDOUBLE  
MOTORSPERIMETER  
ASPIRATIONELECTRIC HOB  
MIN. DISTANCEGAS HOB  
MIN. DISTANCE

## ILLUMINAZIONE/LIGHTING

LAMPADE lamps	2x2,3W Bar Led
TEMPERATURA COLORE color temperature	3500K
INTENSITÀ intensity	260 Lux

## CARATTERISTICHE/FEATURES

2 MOTORI 2 motors
ALLOGGIAMENTO MOTORI POSIZIONATO NELLA PARTE SUPERIORE DEL PENSILE, PER UNA MAGGIORE FRUIBILITÀ DELLO SPAZIO DISPONIBILE Motor housing positioned in the upper part of the wall unit, for greater usability of the available space
CANALE DI ASPIRAZIONE POSIZIONATO POSTERIORMENTE Aspiration channel positioned at the back
TIMER

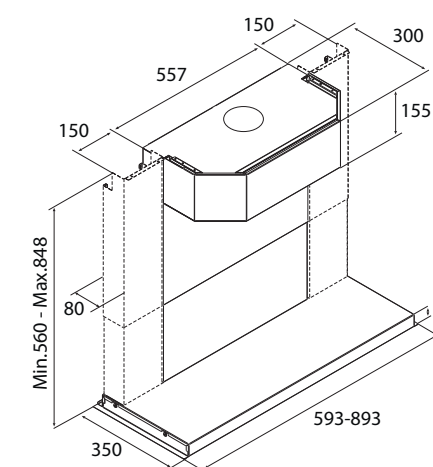



# INNER

## INNER NO DROP

VERSIONE NO DROP CON FILTRI  
BAFFLE E VASCHETTA DI RACCOLTA  
CONDENSA REMOVIBILE.  
NO DROP version with baffle filters  
and removable drip tray.

Il design contemporaneo della veletta dona carattere a Inner, insieme ai praticissimi comandi frontali.

The contemporary design of the film adds character to Inner, along with the practical front controls.



INNER

## PRESTAZIONI/PERFORMANCE

PORTATA IEC Iec air flow	625 M <sup>3</sup> /h
LIVELLO SONORO Noise level	49/59/65 dB(A)
ASSORBIMENTO TOTALE Total absorption	60/90 cm: 224,2W 120 cm: 228,4W

## DATI TECNICI/TECHNICAL DATA

COMANDO Control	PULSANTIERA ELETTRONICA SOFT TOUCH A 4 VELOCITÀ (3+1) 4 speeds soft touch electronic push button (3+1)
FILTRI Filters	FILTRI GRASSO BAFFLE IN ACCIAIO INOX + VASCHETTA DI RACCOLTA ESTRAIBILI LAVABILI Washable metallic grease filters FILTRI ODORI OPTIONAL Odour filters optional
PESO weight	
DIMENSIONI Size	60/90/120 CM
FINITURA finish	ACCIAIO INOX O NERA Stainless steel or black
DIEMNSIONI USCITA ARIA air outlet dimension	ø150 mm
FORATURA cut-out	



ENERGY CLASS



WASHABLE  
GREASE FILTERS



LONG LIFE  
FILTERS



ASPIRATION  
TIMER



ELECTRIC HOB  
MIN. DISTANCE



GAS HOB  
MIN. DISTANCE

## ILLUMINAZIONE/LIGHTING

LAMPADE lamps	60/90 cm: 2x2,1W Led 120 cm: 3x2,1W Led
TEMPERATURA COLORE color temperature	3500K
INTENSITÀ intensity	60/90 cm: 175 Lux 120 cm: 309 Lux

## CARATTERISTICHE/FEATURES

INSTALLAZIONE SEMPLIFICATA  
Easy installation

VELETTA IN VETRO ORIENTABILE CON PROTEZIONE DEL PENSILE E COMANDO FRONTALE INTEGRATO  
Adjustable glass flap with cabinet protection and integrated control

TIMER

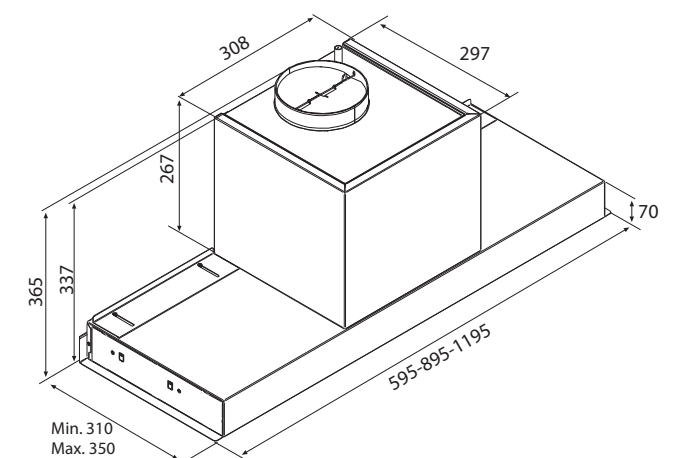

Min. 310  
Max. 350



# COMPACT IN

Immagine rinnovata e prestazioni sempre al top per questo restyling, evoluzione naturale di un prodotto emblematico. Nella versione a incasso.

Renewed image and top performance for this restyling, the natural evolution of an emblematic product. In the flush-mounted version.



COMPACT IN

## PRESTAZIONI/PERFORMANCE

PORTATA IEC Iec air flow	625 M <sup>3</sup> /h
LIVELLO SONORO Noise level	49/59/65 dB(A)
ASSORBIMENTO TOTALE Total absorption	224,6W

## DATI TECNICI/TECHNICAL DATA

COMANDO Control	PULSANTIERA ELETTRONICA SOFT TOUCH A 4 VELOCITÀ (3+1) 4 speeds soft touch electronic push button (3+1)
FILTRI Filters	FILTRI GRASSO METALLICI, LAVABILI Washable metallic grease filters FILTRI ODORI OPTIONAL Odour filters optional
PESO weight	53 cm: 8Kg 83 cm: 12 Kg
DIMENSIONI Size	53/83 CM
FINITURA finish	ACCIAIO INOX O NERA Stainless steel or black
DIEMNSIONI USCITA ARIA air outlet dimension	ø150 mm
FORATURA cut-out	53 cm: 515x265 mm 83 cm: 815x265 mm



ENERGY CLASS

WASHABLE  
GREASE FILTERSLONG LIFE  
FILTERSREMOTE  
CONTROLPERIMETER  
ASPIRATIONASPIRATION  
TIMEREASY  
INSTALLATIONELECTRIC HOB  
MIN. DISTANCEGAS HOB  
MIN. DISTANCE

## ILLUMINAZIONE/LIGHTING

LAMPADE lamps	2x2,3W Bar Led
TEMPERATURA COLORE color temperature	3500 K
INTENSITÀ intensity	53 cm: 260 Lux 83 cm: 240 Lux

## CARATTERISTICHE/FEATURES

INSTALLAZIONE SEMPLIFICATA  
Easy installation

TIMER

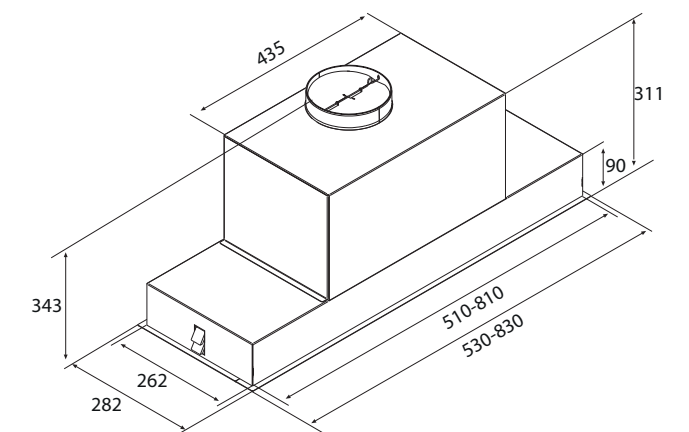





# COMPACT UP

Totamente in sintonia con l'ambiente, la versione a controsoffitto si vede ma non invade, nel rispetto dell'armonia stilistica di ogni soluzione d'arredo.

Totally in tune with the environment, the suspended ceiling version is visible but does not intrude, respecting the stylistic harmony of any furnishing solution.

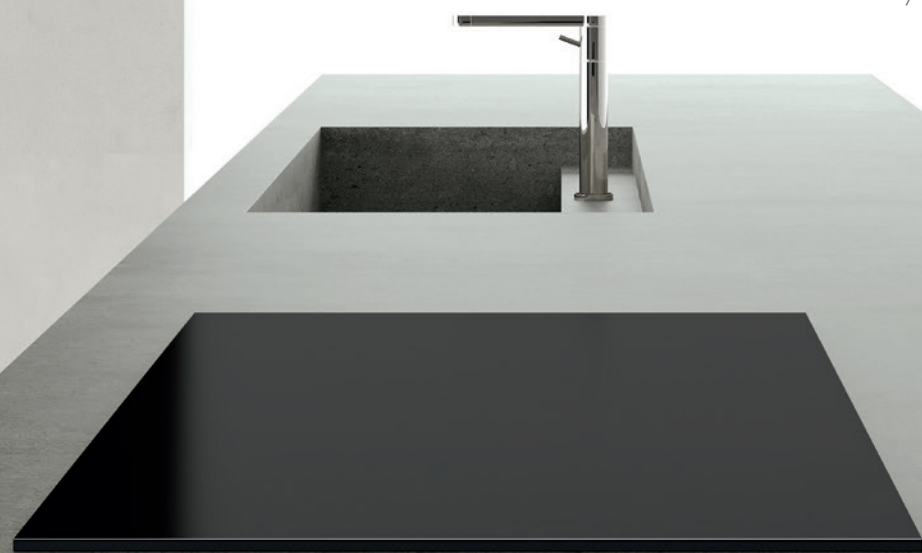

## PRESTAZIONI/PERFORMANCE

PORTATA IEC Iec air flow	625 M <sup>3</sup> /h
LIVELLO SONORO Noise level	49/59/65 dB(A)
ASSORBIMENTO TOTALE Total absorption	224,6W

## ILLUMINAZIONE/LIGHTING

LAMPADE lamps	2x2,3W Bar Led
TEMPERATURA COLORE color temperature	3500 K
INTENSITÀ intensity	240 Lux

## DATI TECNICI/TECHNICAL DATA

COMANDO Control	TELECOMANDO A 4 VELOCITÀ (3+1 INTENSIVA) Remote control 4 speeds (3+1i)
FILTRI Filters	FILTRI GRASSO METALLICI, LAVABILI Washable metallic grease filters FILTRI ODORI OPTIONAL Odour filters optional
PESO weight	12 Kg
DIMENSIONI Size	83 CM
FINITURA finish	ACCIAIO INOX O BIANCA Stainless steel or white
DIEMNSIONI USCITA ARIA air outlet dimension	ø150 mm
FORATURA cut-out	815x265 mm

## CARATTERISTICHE/FEATURES

USCITA ARIA ORIENTABILE, LATERALE O SUPERIORE  
Adjustable air outlet, towards the side or above

VERSIONE MINICEILING: INSTALLAZIONE NEL CONTROSOFFITTO  
Miniceliling version: installation in false ceiling

INSTALLAZIONE SEMPLIFICATA  
Easy installation

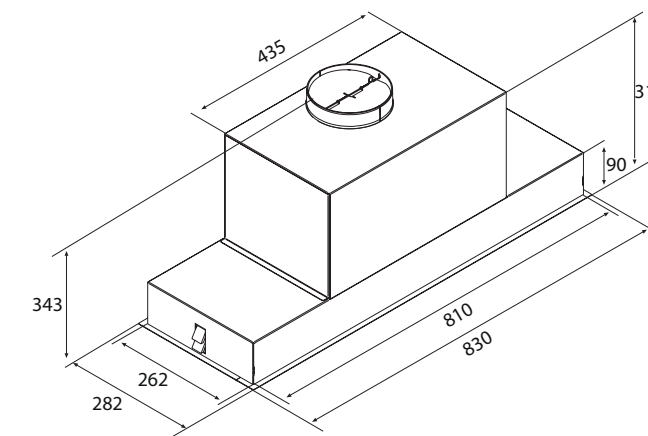
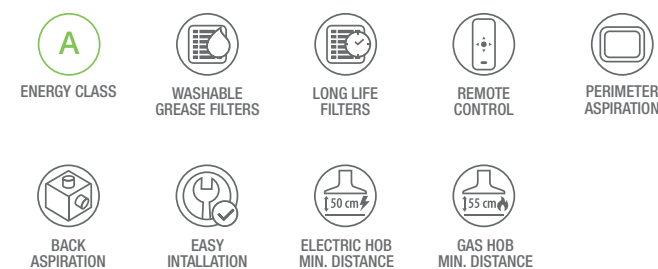

---

# SOFFITTO/ CEILING

I N N O V A   S Y S T E M



# EASY UP & EASY FIT NEW CEILING HOOD PLATFORMS

## EASY UP

**Q**uanta ricchezza dietro le forme pulite di Easy Up. Installabile a controsoffitto, con motore a ingombro standard o ridotto, orientabile in cinque direzioni: perché l'aria segua proprio il percorso che vuoi tu.

**S**o much richness behind the clean shapes of Easy Up. Can be installed in suspended ceilings, with a standard or space-saving motor, swivelling in five directions: so that the air follows exactly the desired direction.



## EASY FIT

**C**ome il nome stesso evoca, la semplicità d'installazione è il leit-motif della piattaforma di cappe ceiling Easy. Grazie al pratico sistema di installazione plug & play, il montaggio è agilissimo e non richiede tubazioni. L'aria filtrata fuoriesce in modalità diffusa dalle aperture superiori, disperdendosi pulita nell'ambiente.

**A**s the name itself evokes, ease of installation is the leitmotif of the Easy hood ceiling platform.

Thanks to the practical plug & play installation system, assembly is very easy and requires no piping. Filtered air escapes in diffuse mode from the upper openings, dispersing cleanly into the room.







---

# SPLIT

EASY UP





# GABRIELLE

## EASY UP



SPLIT - EASY UP

La gamma Easy Up offre ampie opportunità di personalizzazione, grazie alle sei varianti estetiche studiate per chi ama arredare la cucina curando ogni dettaglio: Silhouette, Split, Gabrielle, Sinergia, Raffaello e la nuovissima F2O7.

The Easy Up range offers ample opportunities for customisation, thanks to the six aesthetic variants designed for those who like to furnish their kitchen with an eye to the details: Silhouette, Split, Gabrielle, Sinergia, Raffaello and the brand new F2O7.

### FLAT MOTOR

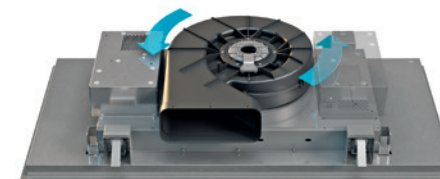

### STANDARD MOTOR

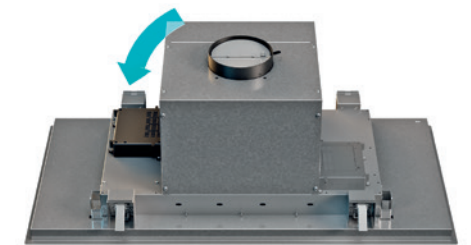



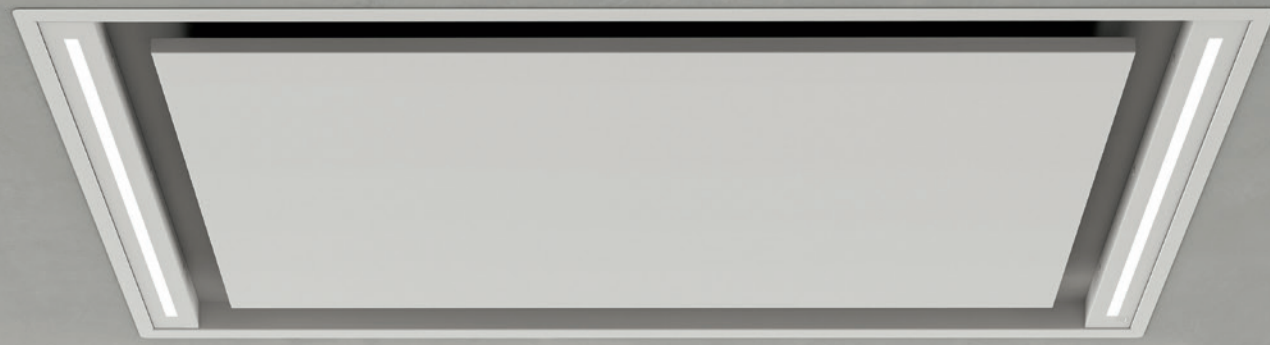

# SILHOUETTE EASY UP

La possibilità di posizionamento remoto del motore asseconda il desiderio di silenzio ed eventuali esigenze specifiche di fuoriuscita dell'aria all'esterno.

The possibility of remote motor positioning meets the need for silence and any specific requirements for air direction outwards.

LOOKING UP  
HAS NEVER BEEN  
SO INTERESTING

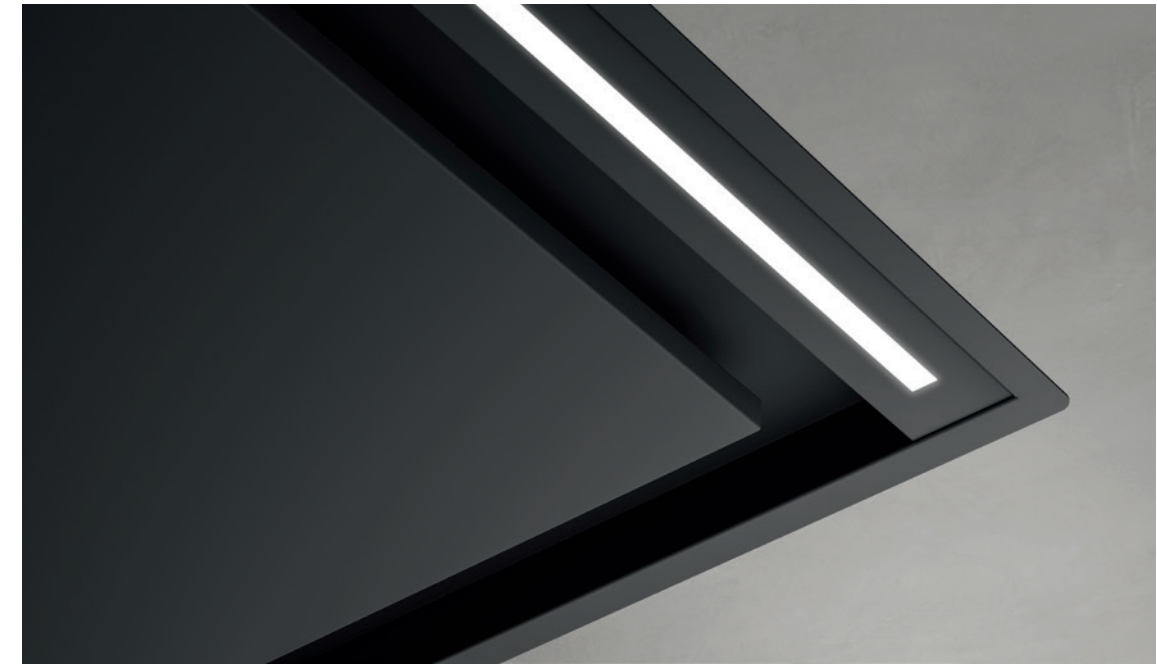

## EASY UP DATI TECNICI/TECHNICAL DATA

PORTATA IEC / Iec air flow	Standard: 630 Flat: 740
LIVELLO SONORO / Noise level	Standard: 47/59/64 dB(A) Flat: 45/65/70 dB(A)
COMANDO / Control	Standard: Telecomando a 4 velocità (3+1) Remote control 4 speeds (3+1) Flat: Telecomando a 6 velocità (5+1) Remote control 6 speeds (5+1)
FILTRI / Filters	FILTRI GRASSO METALLICI, LAVABILI Washable metallic grease filters FILTRI ODORI OPTIONAL Odour filters optional
DIMENSIONI / Size	100X50
DIEMNSIONI USCITA ARIA / Air outlet dimension	Standard: ø150 mm Flat: 222x89 mm
FORATURA / Cut-out	977X477 MM

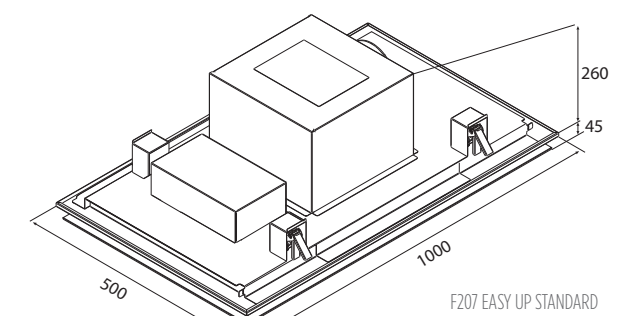
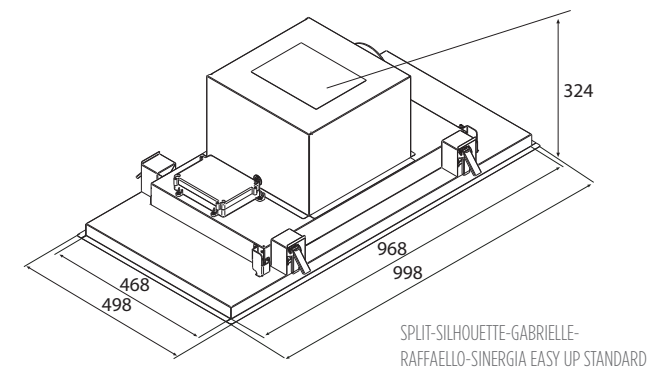
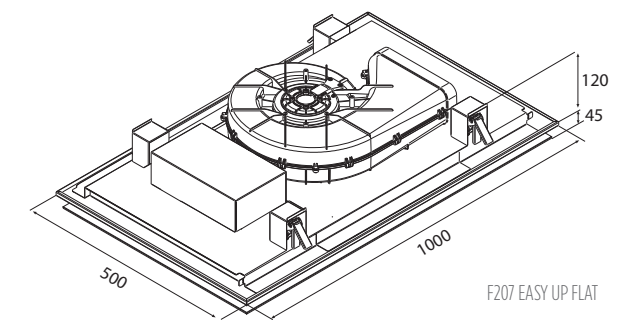
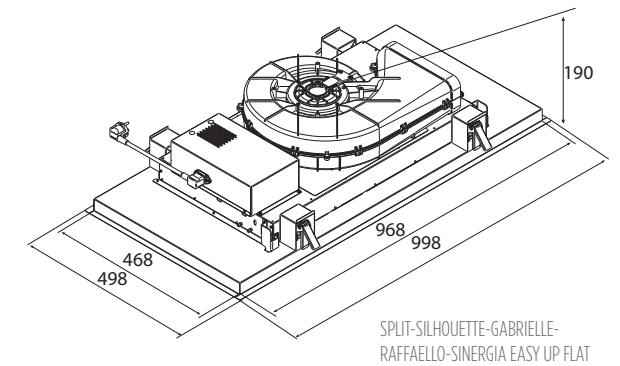



SPLIT - EASY UP

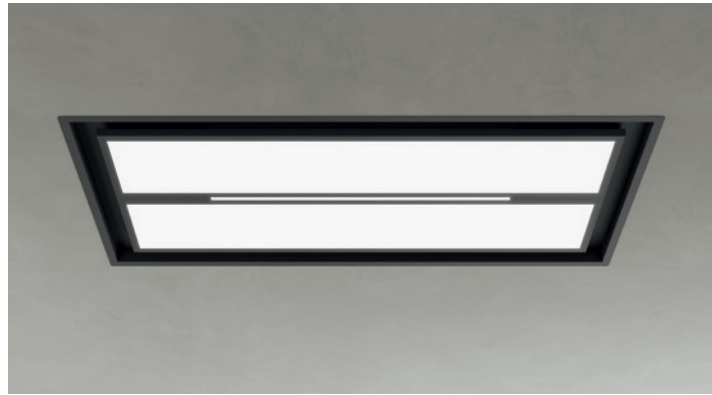

CARATTERISTICHE/FEATURES

DOPPIA ILLUMINAZIONE, LUCE AMBIENTE + LUCE CONCENTRATA SUL PIANO COTTURA, CON CONTROLLO INDIPENDENTE  
Double lighting, ambient light + direct lighting on the hob, with separate control

LUCE AMBIENTE DIMMERABILE / Dimmable ambient light

BIANCO DINAMICO (2700K-6000K) / Tunable white (2700K-6000K)

INSTALLAZIONE SEMPLIFICATA / Easy installation

INSTALLABILE IN CONTROSOFFITTI DI SOLI 19 CM / Installable in false ceiling of only 19 cm

KIT INSTALLAZIONE MOTORE REMOTO DISPONIBILE (OPTIONAL) / Remote motor installation kit available (optional)

DATI TECNICI/TECHNICAL DATA

LAMPADE / Lamps	2x4,2W Bar Led
TEMPERATURA COLORE / Color temperature	4000 K
INTENSITÀ / Intensity	236 Lux
FINITURA / Finish	NERA O BIANCA Black or white
ASSORBIMENTO TOTALE / Total absorption	Standard: 228,4W Flat: 173,4W



F207 - EASY UP

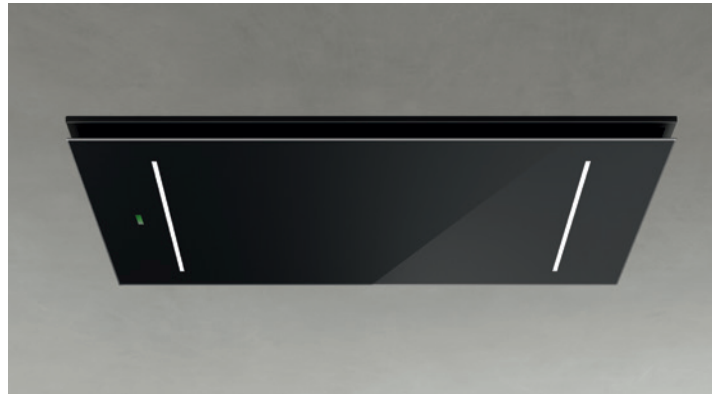

CARATTERISTICHE/FEATURES

INSTALLAZIONE SEMPLIFICATA / Easy installation

INSTALLABILE IN CONTROSOFFITTI DI SOLI 12 CM / Installable in false ceiling of only 12 cm

KIT INSTALLAZIONE MOTORE REMOTO DISPONIBILE (OPTIONAL) / Remote motor installation kit available (optional)

DATI TECNICI/TECHNICAL DATA

LAMPADE / Lamps	2x4,2W Bar Led
TEMPERATURA COLORE / Color temperature	4000 K
INTENSITÀ / Intensity	236 Lux
FINITURA / Finish	NERA O BIANCA Black or white
ASSORBIMENTO TOTALE / Total absorption	Standard: 228,4W Flat: 173,4W

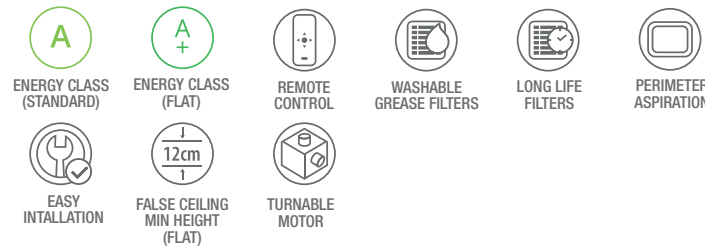

SILHOUETTE - EASY UP



CARATTERISTICHE/FEATURES

INSTALLAZIONE SEMPLIFICATA / Easy installation

INSTALLABILE IN CONTROSOFFITTI DI SOLI 12 CM / Installable in false ceiling of only 12 cm

KIT INSTALLAZIONE MOTORE REMOTO DISPONIBILE (OPTIONAL) / Remote motor installation kit available (optional)

DATI TECNICI/TECHNICAL DATA

LAMPADE / Lamps	2x4,8W Bar Led
TEMPERATURA COLORE / Color temperature	4000 K
INTENSITÀ / Intensity	133 Lux
FINITURA / Finish	ACCIAIO INOX, NERA O BIANCA Stainless steel, black or white
ASSORBIMENTO TOTALE / Total absorption	Standard: 229,6W Flat: 174,6W

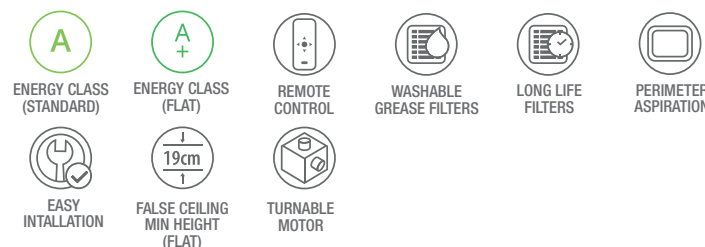

GABRIELLE - EASY UP



CARATTERISTICHE/FEATURES

LUCE AMBIENTE DIMMERABILE / Dimmable ambient light

BIANCO DINAMICO (2700K-6000K) / Tunable white (2700K-6000K)

INSTALLAZIONE SEMPLIFICATA / Easy installation

INSTALLABILE IN CONTROSOFFITTI DI SOLI 19 CM / Installable in false ceiling of only 19 cm

KIT INSTALLAZIONE MOTORE REMOTO DISPONIBILE (OPTIONAL) / Remote motor installation kit available (optional)

DATI TECNICI/TECHNICAL DATA

LAMPADE / Lamps	22,4W Led Panel
TEMPERATURA COLORE / Color temperature	2700K-6000K
INTENSITÀ / Intensity	349 Lux
FINITURA / Finish	ACCIAIO INOX Stainless steel
ASSORBIMENTO TOTALE / Total absorption	Standard: 242,5W Flat: 187,5W

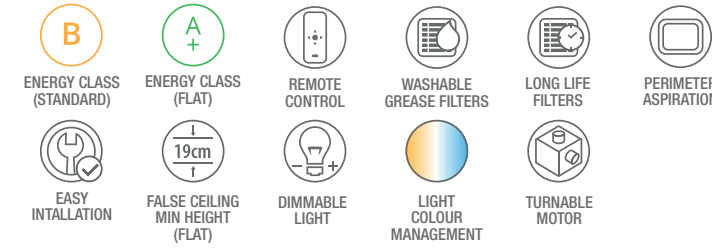

SINERGIA - EASY UP

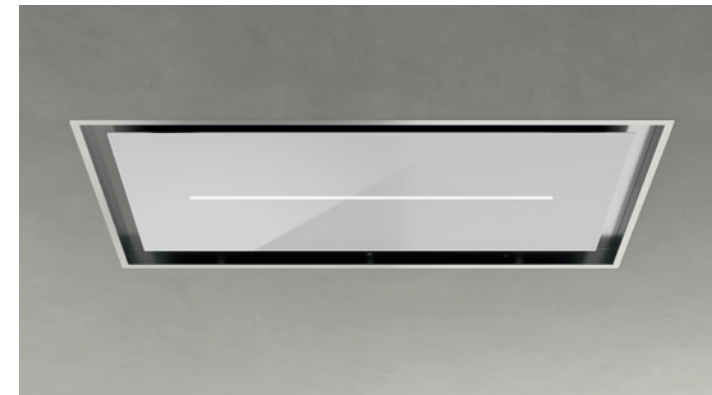

CARATTERISTICHE/FEATURES

INSTALLAZIONE SEMPLIFICATA / Easy installation

INSTALLABILE IN CONTROSOFFITTI DI SOLI 19 CM / Installable in false ceiling of only 19 cm

KIT INSTALLAZIONE MOTORE REMOTO DISPONIBILE (OPTIONAL) / Remote motor installation kit available (optional)

DATI TECNICI/TECHNICAL DATA

LAMPADE / Lamps	7,8W Bar Led
TEMPERATURA COLORE / Color temperature	4000 K
INTENSITÀ / Intensity	190 Lux
FINITURA / Finish	ACCIAIO INOX CON VETRO NERO O BIANCO Stainless steel with black or white glass
ASSORBIMENTO TOTALE / Total absorption	Standard: 227,8W Flat: 172,8W

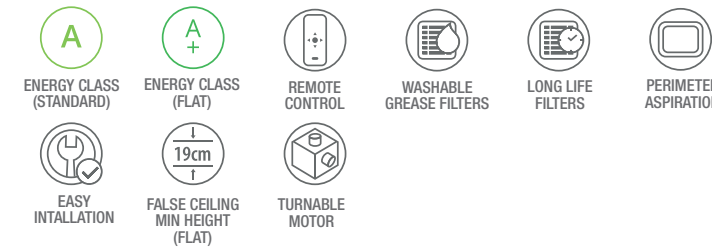

RAFFAELLO - EASY UP



CARATTERISTICHE/FEATURES

VERNICIABILE / Paintable

INSTALLAZIONE SEMPLIFICATA / Easy installation

INSTALLABILE IN CONTROSOFFITTI DI SOLI 19 CM / Installable in false ceiling of only 19 cm

KIT INSTALLAZIONE MOTORE REMOTO DISPONIBILE (OPTIONAL) / Remote motor installation kit available (optional)

DATI TECNICI/TECHNICAL DATA

FINITURA / Finish	ACCIAIO INOX, VERNICIABILE Stainless steel, paintable
ASSORBIMENTO TOTALE / Total absorption	Standard: 220W Flat: 165W





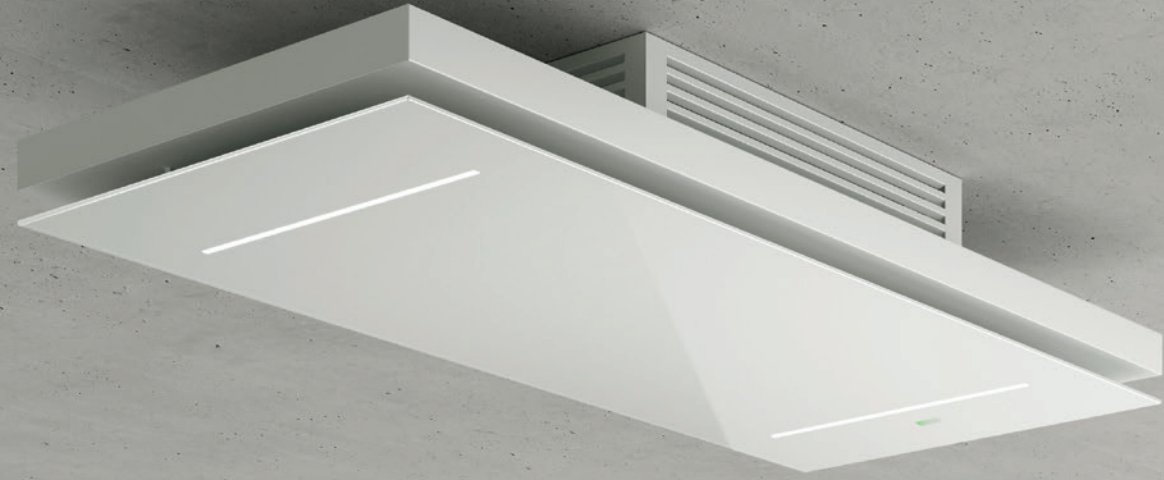

---

F207  
EASY FIT





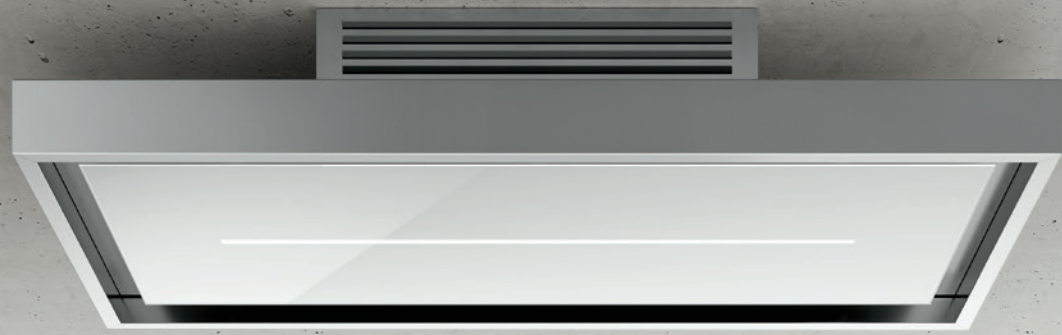

# SINERGIA

## EASY FIT



La Easy Fit offre ampie opportunità di personalizzazione, grazie alle tre varianti estetiche studiate per chi ama arredare la cucina curando ogni dettaglio: Silhouette, Sinergia e la nuovissima F207.

Easy Fit offers ample opportunities for customisation, thanks to the three aesthetic variants designed for those who like to furnish their kitchen with an eye to the details: Silhouette, Sinergia and the brand new F207.



### EASY FIT DATI TECNICI/TECHNICAL DATA

PORTATA IEC / Iec air flow	550
LIVELLO SONORO / Noise level	55/67/70 dB(A)
COMANDO / Control	Telecomando a 4 velocità (3+1) Remote control 4 speeds (3+1)
FILTRI / Filters	FILTRI GRASSO METALLICI, LAVABILI Washable metallic grease filters FILTRI ODORI INCLUSI Odour filters included
DIMENSIONI / Size	100X50

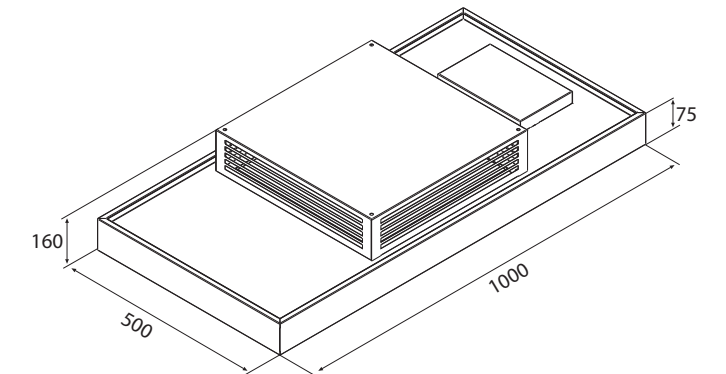

SILHOUETTE EASY FIT

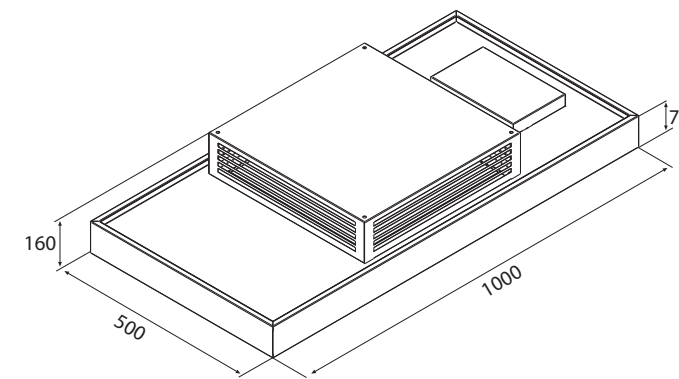

SINERGIA EASY FIT

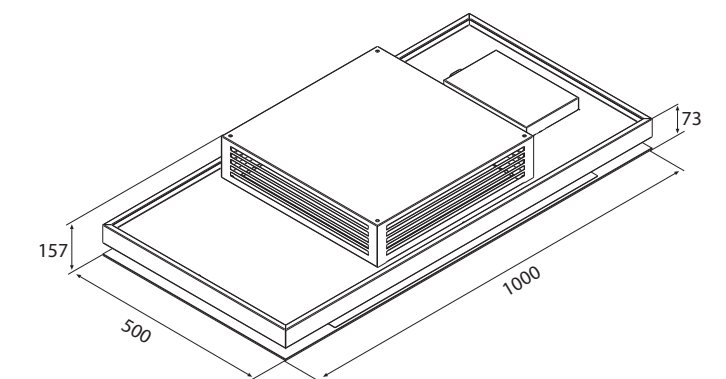

F207 EASY FIT





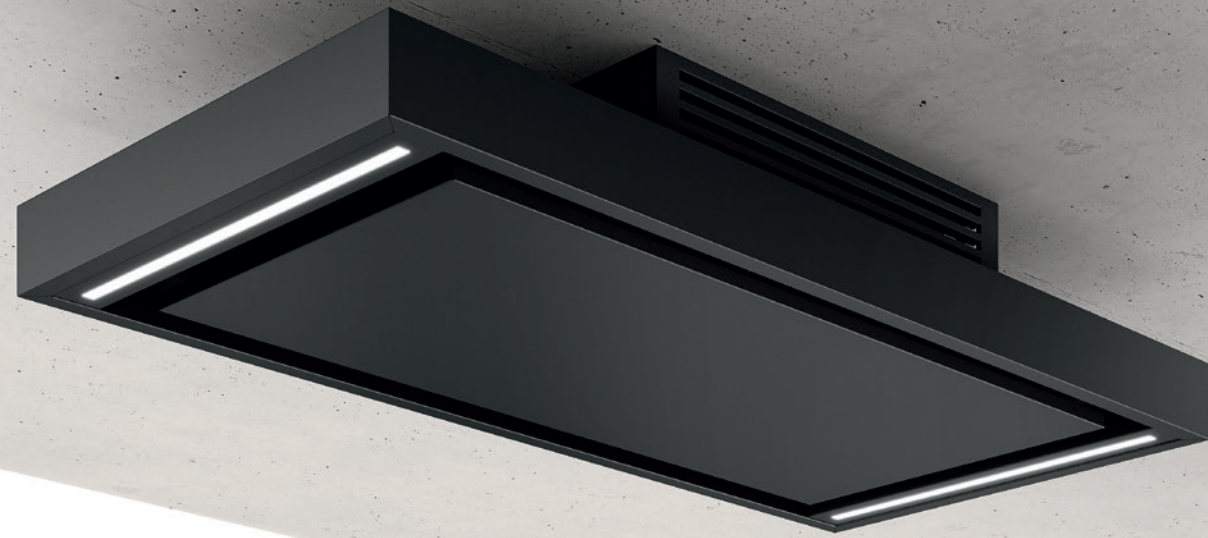

SILHOUETTE - EASY FIT

THE BEAUTY  
OF MAKING  
IT EASY



F207 - EASY FIT



-   
RECIRCULATION ONLY
-   
REMOTE CONTROL
-   
WASHABLE GREASE FILTERS
-   
LONG LIFE FILTERS
-   
PERIMETER ASPIRATION
-   
EASY INTALLATION

CARATTERISTICHE/FEATURES

INSTALLABILE SENZA CONTROSOFFITTO Installable without false ceiling	
SOLO FILTRANTE Recirculation only	
FILTRI ODORI INCLUSI Odour filters included	
LAMPADE / Lamps	2x4,2W Bar Led
TEMPERATURA COLORE / Color temperature	4000K
INTENSITÀ / Intensity	236 Lux
FINITURA / Finish	NERA O BIANCA Black or white
ASSORBIMENTO TOTALE / Total absorption	93,4W

SINERGIA - EASY FIT



-   
RECIRCULATION ONLY
-   
REMOTE CONTROL
-   
WASHABLE GREASE FILTERS
-   
LONG LIFE FILTERS
-   
PERIMETER ASPIRATION
-   
EASY INTALLATION

CARATTERISTICHE/FEATURES

INSTALLABILE SENZA CONTROSOFFITTO Installable without false ceiling	
SOLO FILTRANTE Recirculation only	
FILTRI ODORI INCLUSI Odour filters included	
LAMPADE / Lamps	7,8W Bar Led
TEMPERATURA COLORE / Color temperature	4000 K
INTENSITÀ / Intensity	190 Lux
FINITURA / Finish	ACCIAIO INOX CON VETRO NERO O BIANCO Stainless steel with black or white glass
ASSORBIMENTO TOTALE / Total absorption	92,8W

SILHOUETTE - EASY FIT



-   
RECIRCULATION ONLY
-   
REMOTE CONTROL
-   
WASHABLE GREASE FILTERS
-   
LONG LIFE FILTERS
-   
PERIMETER ASPIRATION
-   
EASY INTALLATION

CARATTERISTICHE/FEATURES

INSTALLABILE SENZA CONTROSOFFITTO Installable without false ceiling	
SOLO FILTRANTE Recirculation only	
FILTRI ODORI INCLUSI Odour filters included	
LAMPADE / Lamps	2x4,2W Bar Led
TEMPERATURA COLORE / Color temperature	4000K
INTENSITÀ / Intensity	133 Lux
FINITURA / Finish	ACCIAIO INOX, NERA O BIANCA Stainless steel, black or white
ASSORBIMENTO TOTALE / Total absorption	94,6W



**Airforce S.p.A.**

Via Venza Volgore 3/A  
60043 Cerreto d'Esi (AN) Italia  
Tel. +39 0732 098101  
info@airforcespa.com  
[www.airforcespa.it](http://www.airforcespa.it)

**PUBBLICAZIONE EDITORIALE  
A CURA DI MARKETING E  
COMUNICAZIONE AIRFORCE**  
EDITORIAL PUBLICATION BY AIRFORCE

PRODUCT DESIGN  
**Fabrizio Nizi**  
**Airforce Design Center**

CONCEPT  
**Airforce in collaboration  
with Communication Lab**

AD, GRAPHIC DESIGN, COPY,  
3D IMAGES AND PHOTO EDITOR  
**Communication Lab**

COLOUR SEPARATION  
**Studio 59 Prepress**

PRINT  
**bBold**

MADE WITH PASSION IN ITALY

IL CATALOGO, LE IMMAGINI E TUTTI I CONTENUTI SONO DI PROPRIETÀ DI AIRFORCE S.P.A. TUTTI I DIRITTI SONO RISERVATI. È VIETATA OGNI FORMA DI RIPRODUZIONE ANCHE PARZIALE.  
The catalogue, images and all contents are the property of airforce s.p.a. All rights are reserved. Any form of reproduction, even partial, is prohibited.

NEL CASO IN CUI UN PRODOTTO SIA DISPONIBILE IN PIÙ MISURE E/O VERSIONI, I DATI TECNICI SONO RIFERITI ALLA MISURA E/O VERSIONE MOSTRATA NELLE IMMAGINI.  
In the event that a product is available in several sizes and/or versions, the technical data refer to the measure and/or version shown in the images.

AIRFORCE S.P.A. SI RISERVA IL DIRITTO DI EFFETTUARE MODIFICHE AI SUOI PRODOTTI E/O ALLE LORO CARATTERISTICHE SENZA ALCUN PREAVVISO.  
AIRFORCE S.p.A. reserves the right to modify its products and/or technical specifications without any warning.



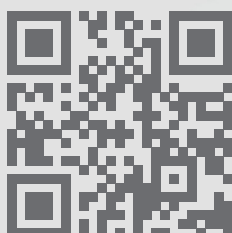

AIRFORCE S.P.A.

Via Venza Volgore, 3/A  
60043 - Cerreto D'esi (AN) - Italia  
Tel. +39 0732 098101  
[www.airforcespa.it](http://www.airforcespa.it)

